

Wilkerson® FRLs R08-Series Miniature Regulators

Features

- 0-125 PSI adjusting range
- Balanced valve design
- Self-relieving standard
- Non-rising push/pull locking adjustment knob
- Two 1/8" NPT gauge ports standard on models without gauge, one 1/8" NPT gauge port standard on models with gauge – can be used for additional outlet ports.
- Models with gauge are supplied with a 0-160 PSI flush mount style gauge
- Models supplied without gauge use a GC620 gauge.
- Panel mount nuts sold separately



Specifications

- Maximum operating conditions:
300 PSIG (20.7 bar) and -4°F to 150°F (-20°C to 65.5°C)

Size	Flow (SCFM)	With Gauge Part #
1/4"	68	R08-02RG

NOTE: SCFM ratings at 100 PSIG inlet pressure.

RB3-Series Miniature Water Regulators

Features

- 2-125 PSI adjusting range
- Suitable for water and compressed air service
- Brass construction – wetted parts
- Non-relieving spring-loaded diaphragm
- Panel mount nut included
- Two 1/8" NPT gauge ports standard
- Models supplied without gauge use a GC620 gauge



Specifications

- Maximum operating conditions:
300 PSIG (20.7 bar) and 40°F to 125°F (4°C to 52°C)

Size	Flow (SCFM)	With Gauge Part #	Without Gauge Part #
1/8"	14	RB3-01RG	RB3-01R
1/4"	14	RB3-02RG	RB3-02R

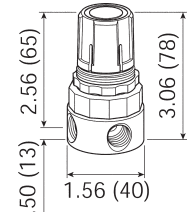

NOTE: See pages 322-326 for accessories.
SCFM ratings at 100 PSIG inlet pressure.

BB3-Series Miniature Filters/Regulators

Features

- 2-125 PSI adjusting range
- 5 micron element
- .4 oz. bowl
- Self-relieving
- Supplied with a GC620 gauge

Specifications

- Maximum operating conditions:
 - transparent bowl: 150 PSIG (10.37 bar) and 40°F to 125°F (4.4°C to 52°C)
 - metal bowl: 300 PSIG (20.7 bar) and 40°F to 125°F (4.4°C to 52°C)

Port Size	Flow (SCFM)	Transparent Bowl		Metal Bowl	
		Automatic Drain Part #	Manual Drain Part #	Automatic Drain Part #	Manual Drain Part #
1/8"	13	---	BB3-01MG	---	BB3-01MGMB
1/4"	16	BB3-02AG	BB3-02MG	---	BB3-02MGMB

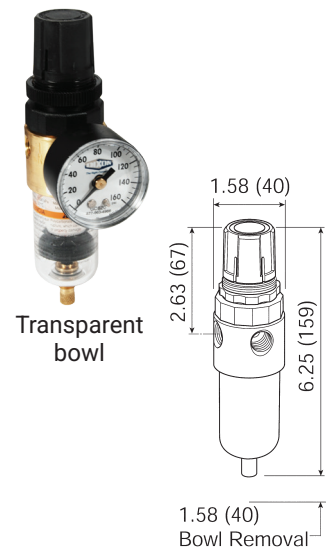

NOTE: SCFM ratings at 100 PSIG inlet pressure.
FRLs are designed for air service only, unless otherwise indicated.

